

# PS.R2 PRECISION BALANCES



release date 23-12-2014



PS.R2 series balances represent a new standard of precision balances. They **feature a new, readable LCD display** which allows a clearer presentation of the weighing result. Besides, the display has a new text information line allowing to show additional messages and data, e.g. product name or tare value.

New PS.R2 balances, like previously designed PS series balances, have pans in two possible dimensions: 128x128 mm or 195x195 mm. balances with a smaller pan have a draft shield. The balance precision and the measurement accuracy is assured by **automatic internal adjustment**, which takes into consideration temperature changes and time flow.

PS.R2 balances feature several communication interfaces: **2 x RS 232, type A USB, type B USB and optional WiFi**. The housing is made of plastic, and the pan is made of stainless steel. The balances have a possibility to weigh products out of the pan (under hook weighing) - the load hangs under the pan.

-  Weighing
-  Parts counting
-  Checkweighing
-  Percent setup
-  Filling
-  Summing function
-  Statistics
-  Density determination
-  Animal weighing
-  Caps lock of max indication
-  Under-hook weighing

## DATABASES IN R SERIES BALANCES

The information system is based on 5 databases, which allows for several users to work with several products databases, and the registered weighing results can be subject to further analysis.

### The data is registered in 5 databases:

- users (up to 10 users),
- products (up to 1000 products),
- weighments (up to 1000 weighments),
- tares (up to 10 tares),
- ALIBI memory (up to 100 000 weighments).

There is two directions data exchange within the system thanks to a quick USB interface. New balances allow to import and export databases using USB pen drives.

## Quick access to information

Direct access to functions and databases is possible from the level of keyboard.

**Database** – a direct access to databasis

**Function** - a direct access to the basic functions

**F1 to F4** – programmable function and navigation keys on the menu

## ALIBI memory

The used ALIBI memory is a data secure area and allows to record up to 100 000 weighment records. It ensures security of constant data register in the long time period.

## Technical data:

	PS 200/2000.R2 <b>M</b>	PS 210.R2 <b>M</b>	PS 360.R2 <b>M</b>	PS 600.R2 <b>M</b>	PS 750.R2 <b>M</b>	PS 1000.R2 <b>M</b>
Max capacity	200 / 2000 g	210 g	360 g	600 g	750 g	1010 g
Minimum load	20 mg	20 mg	20 mg	20 mg	20 mg	20 mg
Readability	1 / 10 mg	1 mg	1 mg	1 mg	1 mg	1 mg
Tare range	-2000 g	-210 g	-360 g	-600 g	-750 g	-1010 g
Repeatability *	1 / 10 mg	1 mg	1 mg	1 mg	1,5 mg	1,5 mg
Linearity	±2 / ±20 mg	±2 mg	±2 mg	±3 mg	±3 mg	±3 mg
Pan size	128x128 mm					
Working temperature	+10 ÷ +40 °C					
Stabilization time	2 s / 1,5 s	2 s				
Sensitivity drift	2 ppm/°C in temperature +10 ÷ +40 °C					
Interface	2 x RS 232, USB-A, USB-B, WiFi - option					
Power supply**	12 ÷ 16 V DC / 2,1 A					
Adjustment/calibration	internal (automatic)					
Display	LCD (backlit)					
Net weight/Gross weight	3,5 / 5,5 kg	3,5 / 5,5 kg	3,5 / 5,5 kg	3,5 / 5,5 kg	3,5 / 5,5 kg	3,5 / 5,5 kg
Packaging size	470x380x336 mm					

\* Repeatability is expressed as a standard deviation from 10 weighing cycles.

\*\* 250 mA for balances without WiFi module, 350 mA for balances with installed WiFi module

## Technical data:

	PS 1200.R2 <b>M</b>	PS 2100.R2 <b>M</b>	PS 3500.R2 <b>M</b>	PS 4500.R2 <b>M</b>	PS 6000.R2 <b>M</b>
Max capacity	1200 g	2100 g	3500 g	4500 g	6000 g
Minimum load	500 mg	500 mg	500 mg	500 mg	500 mg
Readability	10 mg	10 mg	10 mg	10 mg	10 mg
Tare range	-1200 g	-2100 g	-3500 g	-4500 g	-6000 g
Repeatability *	10 mg	10 mg	10 mg	10 mg	15 mg
Linearity	±20 mg	±20 mg	±20 mg	±20 mg	±30 mg
Pan size	195×195 mm				
Working temperature	+10 ÷ +40 °C				
Stabilization time	1,5 s				
Sensitivity drift	2 ppm/°C in temperature +10 ÷ +40 °C				
Interface	2 × RS 232, USB-A, USB-B, WiFi - option				
Power supply**	12 ÷ 16 V DC / 2,1 A				
Adjustment/calibration	internal (automatic)				
Display	LCD (backlit)				
Net weight/Gross weight	3,6 / 5,1 kg	3,6 / 5,1 kg	3,6 / 5,1 kg	3,6 / 5,1 kg	3,6 / 5,1 kg
Packaging size	470×380×336 mm				

\* Repeatability is expressed as a standard deviation from 10 weighing cycles.

\*\* 250 mA for balances without WiFi module, 350 mA for balances with installed WiFi module

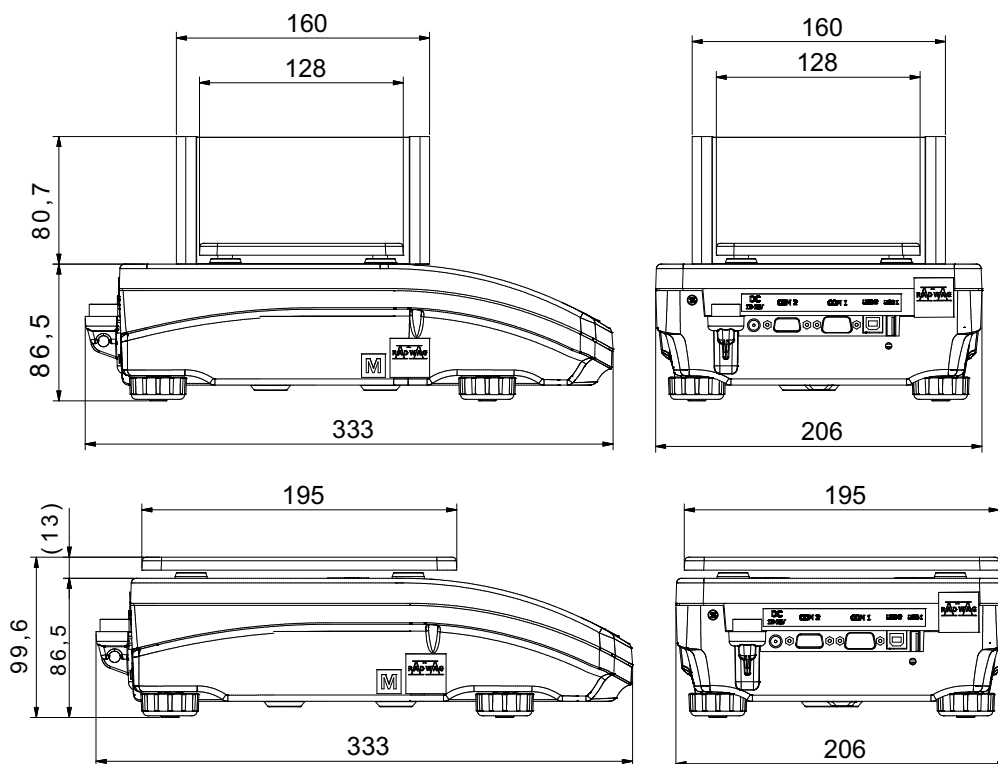

## Accessories:

Antivibration table for laboratory balances	Bar code scanner USB HID
Antivibration table SAL/STONE	Power loop output AP2-1 (plastic housing)
Kafka thermal printer	Additional LCD display "WD-6"
Impact printer Epson	Power adapter with battery and charger ZR-02
Label printer Citizen	Mass standard
Printer USB PCL	Szafka przeciwpodmuchowa (do wag z szalką 128x128)
Density determination kit	USB A- USB B cable (balance - computer, balance - PLC printer)
Rack for under hook weighing	Cable RS 232 (scale - Kafka printer) "P0136"
"Tare" or "Print" foot button	Cable RS 232 (scale - computer) "P0108"
PC keyboard USB	Cable RS 232 (scale, Epson, Citizen printer) "P0151"
External USB memory (FAT files format)	"PW-WIN" computer software
Bar code scanner	"RAD-KEY" computer software

## RADWAG Balances & Scales

26-600 Radom • 28 Bracka Street • POLAND • Phone: +48 48 3848800 • Fax: +48 48 3850010 • www.radwag.com • e-mail: export@radwag.com