



HY10.HRP, the series of professional high resolution scales, perfectly suits every single branch of industry requiring great weighing accuracy, precision and repeatability of measurement in challenging industrial environment.

Automatic adjustment performed by means of an internal adjustment weight guarantees the highest quality of operation and repeatability of measurement. In comparison to manual adjustment process the automatic one is both, time-saving and convenient.

Data safety and archiving is assured by software dedicated for RADWAG terminals.

Features:

- ✓ Brand new design of an electromagnetic mechanism housed in a dustproof and waterproof casing
- ✓ Overload protection
- ✓ An in-built adjustment system equipped with an internal adjustment weight
- ✓ High IP rating for the terminal, IP68/69, and the platform, IP67
- ✓ Interfaces: RS 232, USB, Ethernet and customized 4 INs and 4 OUTs for cooperation with peripherals

Technical specification:

	HY10.16.HRP	HY10.32.HRP	HY10.62.HRP	HY10.120.HRP
Max capacity [Max]	16 kg	32 kg	62 kg	120 kg
Minimum load [Min]	5 g	5 g	25 g	50 g
Reading unit [d]	0,1 g	0,1 g	0,5 g	1 g
Tare range	-16 kg	-32 kg	-62 kg	-120 kg
Preload range	4 kg	4 kg	30 kg	10 kg
Repeatability *	0,1 g	0,1 g	0,3 g	0,6 g
Linearity	± 0,1 g	± 0,3 g	± 1 g	± 1 g
Weighing pan	360 × 280 mm	360 × 280 mm	500 × 500 mm	500 × 500 mm
Working temperature	+10° ÷ +40 °C			
Relative humidity **	40% ÷ 80%			
IP rate	IP 66/67 construction, IP 68/69 indicator			
Housing	Balance base: powder-coated aluminium, weighing pan: stainless steel		Construction: Plastic-coated steel, Weighing pan: stainless steel	
Stabilization time ***	~ 2 s		~ 3 s	
Sensitivity drift	2 ppm/°C in temperature +10° ÷ +40°C			
LCD display	10,1" touch panel			
Standard interfaces	2×RS 232, 2×USB, 1×Ethernet, 4 IN / 4 OUT			
Optional interfaces	Module 12 × IN / 12 × OUT, Module AN, Module PROFIBUS, Module CAN Open, Wireless Module, RS485			
Power supply	100÷240 V AC 50÷60 Hz			
Adjustment	internal			
Net weight / Gross weight	20,3 kg / 25,6 kg		37 kg / 47 kg	
Platform dimensions	365×312×138,5 mm		513×500×150 mm	
Platform/terminal packaging dimensions	550×463×350 mm / 415×345×225 mm		700×700×295 mm / 415×345×225 mm	

* - Repeatability is expressed as a standard deviation from 10 weighing cycles

** - Non-condensing conditions

*** - Optimal ambient conditions

Technical specification:

	HY10.150.HRP	HY10.300.HRP	HY10.300.1.HRP	HY10.600.HRP	HY10.1100.HRP
Max capacity [Max]	150 kg	300 kg	300 kg	600 kg	1100 kg
Minimum load [Min]	50 g	100 g	100 g	250 g	500 g
Reading unit [d]	1 g	2 g	2 g	5 g	10 g
Tare range	-150 kg	-300 kg	-300 kg	-600 kg	-1100 kg
Preload range	30 kg	60 kg	60 kg	60 kg	100 kg
Repeatability *	1,5 g	3 g	3 g	7,5 g	15 g
Linearity	± 3 g	± 6 g	± 6 g	± 15 g	± 30 g
Weighing pan	800 × 600 mm	800 × 600 mm	1000 × 800 mm	1000 × 800 mm	1000 × 800 mm
Working temperature	+10° ÷ +40 °C				
Relative humidity **	40% ÷ 80%				
IP rate	IP 66/67 construction, IP 68/69 indicator				
Housing	Construction: Plastic-coated steel, Weighing pan: stainless steel				
Stabilization time ***	~ 3 s				
Sensitivity drift	2 ppm/°C in temperature +10° ÷ +40°C				
LCD display	10,1" touch panel				
Standard interfaces	2×RS 232, 2×USB, 1×Ethernet, 4 IN / 4 OUT				
Optional interfaces	Module 12 × IN / 12 × OUT, Module AN, Module PROFIBUS, Module CAN Open, Wireless Module, RS485				
Power supply	100÷240 V AC 50÷60 Hz				
Adjustment	internal				
Net weight / Gross weight	71,5 kg / 119 kg		126 kg / 160 kg		
Platform dimensions	808×600×173 mm		1011×800×175 mm		
Platform/terminal packaging dimensions	1000×800×307 mm / 415×345×225 mm		1200×1000×328 mm / 415×345×225 mm		

* - Repeatability is expressed as a standard deviation from 10 weighing cycles

** - Non-condensing conditions

*** - Optimal ambient conditions

Dimensions:

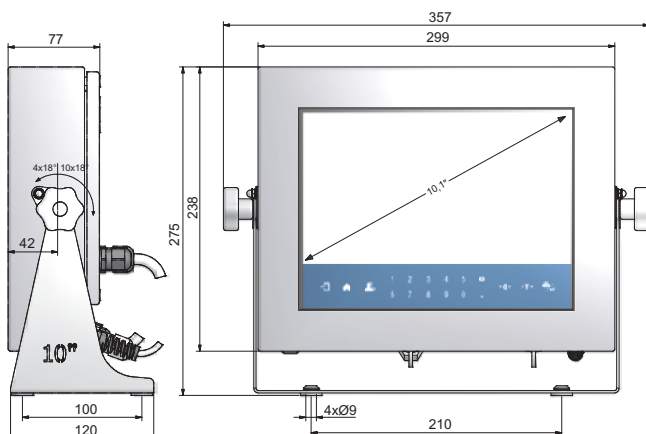
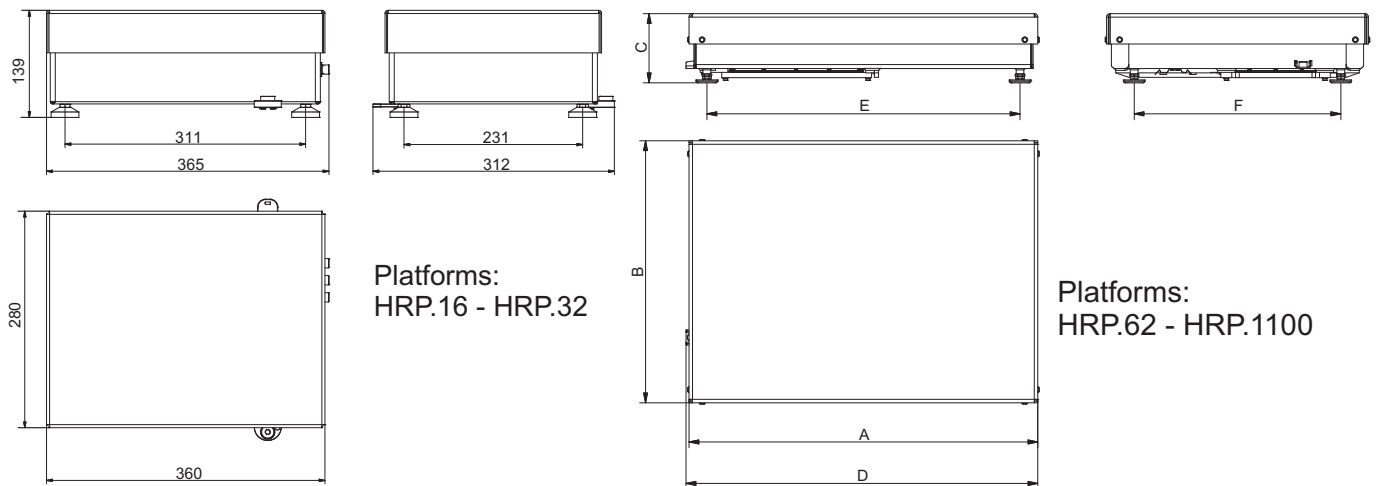

Model	A	B	C	D	E	F
HY10.62.HRP	500	500	147	513	448	400
HY10.120.HRP	500	500	147	513	448	400
HY10.150.HRP	800	600	159	809	720	475
HY10.300.HRP	800	600	164	809	720	475
HY10.300.1.HRP	1000	800	176	1011	926	611
HY10.600.HRP	1000	800	176	1011	926	611
HY10.1100.HRP	1000	800	176	1011	926	611

Additional equipment:

Impact printers:	Barcode scanners:
EPSON TM-U220D – standard version	LS2208 – intended for standard operating conditions, standard version
EPSON TM-U220B – with an autocutter	PowerScan D8330 – intended for severe operating conditions IP56
EPSON TM-U220A – with an autocutter and a copy-winder	PowerScan M8300 – intended for severe operating conditions IP56 cordless system
Label printers:	Transponder card readers:
CITIZEN CL-S521	CK-01/3
CITIZEN CL-S621	CK-02/3
CITIZEN CL-S631	CABLES:
CITIZEN CL-S700	PT0087 – for EPSON, CITIZEN and other printers on USB
CITIZEN CL-S700R	PT0212 – straight-thru Ethernet cable with RJ45 connector
ZEBRA GK 420d	WEIGHTS:
ZEBRA GK 420t	Mass standard
ZEBRA GX 420t	Adjustment weight
ZEBRA GX 430t	MISCELLANEOUS EQUIPMENT:
ZEBRA ZT 220	TARE / PRINT foot button
ZEBRA ZT 41042	