

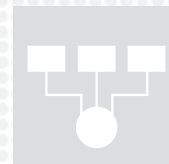

Your partner in inspection and quality control



checkweigher + metal detector 08D3 integrated compact



Your partner in inspection and quality control



go to the web-page dedicated to this product



checkweigher
+ metal detector

08D3 integrated compact

Equipment

- Digital electronics with alphanumeric graphic display
- Electronic self-calibration device
- 3 levels password access protection
- Mobile average function
- 100 storable product programs
- One RS232 serial ports
- Total printouts
- Automatic balancing
- Report archive
- Fail-safe mode
- Principle of operation: digital with bidimensional image
- Phase adjustment function
- Working multifrequency
- Function and process alarm output
- Automatic product compensation (Tracking)
- Visualization of product image
- Self-check function
- In conformity with ISO - FDA - HACCP - GMP regulations
- High immunity to environmental interferences
- Production data management in conformity with the standards in force
- Very high sensibility to all magnetic and not magnetic metals, stainless included

Optional

- Ejection systems
- Reject management systems
- Stainless steel rejection bin
- Wind-prevention tunnel
- 24-columns panel printer
- Alarms notification
- Separated electronic equipment
- Ethernet interface
- USB interface
- Products programs memory expansion
- Feed-back function
- FAT/SAT, IQ/OQ validations
- MID Certification (version with metal detector panel control)

Technical Specifications

08D3 integrated compact

Weighing range	up to 1600 g
Display division	from 0,5 g
Linear speed	up to 100 m/min
Throughput	up to 300 ppm
Accuracy*	from $\pm 0,5$ g
Pneumatic supply	0,6 Mpa
Air consumption (for ejection)	1 Nl
Power supply	230V 50/60Hz single phase
Power consumption	700 W
Mirror finishing of metal parts	Stainless Steel IP54 - IP65
Climatic environment	from 5°C up to +40°C non-condensing (closed)

*depending on the weight, dimensions and type of product

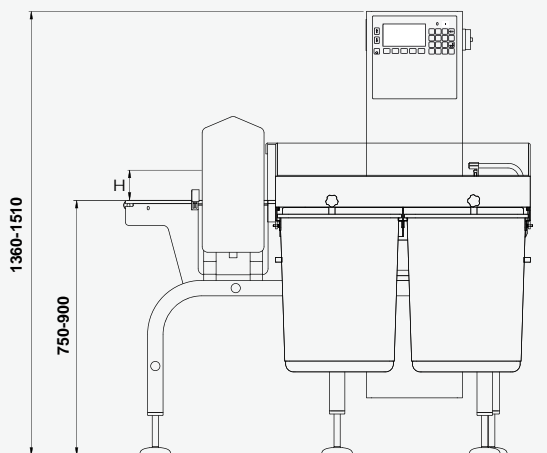

RUNNING DIRECTION TO CLIENT'S SPECS

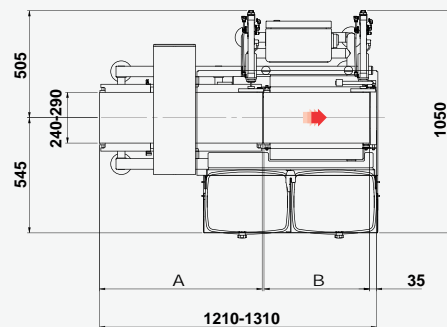

Configurations		
Metal Detector Opening Height	Metal Detector Conveyor	Weighing Plate
H	A	B
100	670	500
150	770	500
200	770	500



The manufacturer reserves the right to change the product specifications without notice. The image and the drawing are indicative of one of the possible configurations of the machine.

PRISMA INDUSTRIALE S.r.l.

Via La Bionda, 17 - 43036 Fidenza - Parma - Italy • Tel. +39 0524 527270 - Fax +39 0524 524142
www.prismaindustriale.com • info@prismaindustriale.com