

UNIQUE, PATENTED & COST EFFECTIVE SOLUTION FOR PROCESS WEIGHING APPLICATIONS

capacities 5kg - 5000kg

NEW
2500kg
CAPACITY

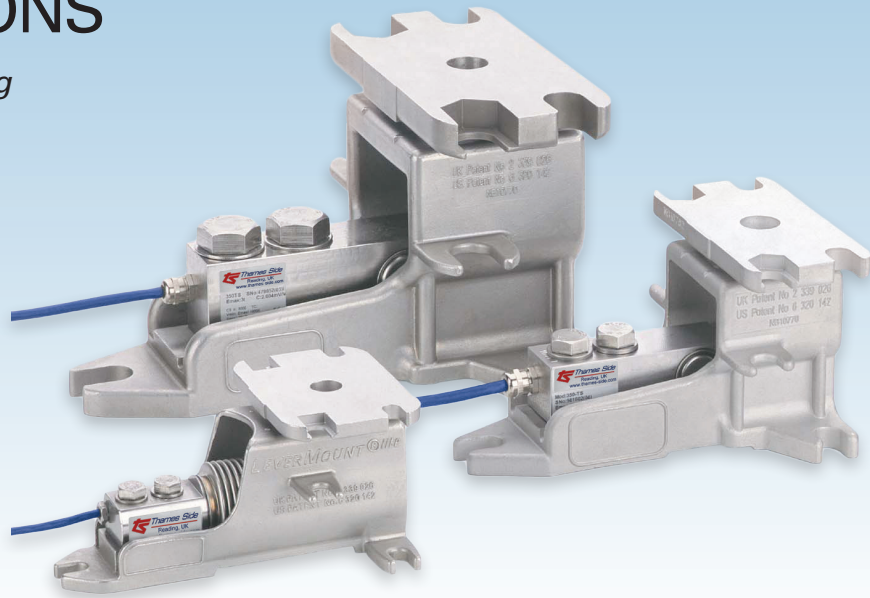

The LeverMount® is a unique, well-established load cell weighing assembly that makes installation much simpler, safer and more cost-effective than traditional assemblies. Its innovative design allows for fast load cell installation without any jacking tools or dummy (false) load cells – even with a loaded tank/hopper. It is available in 3 sizes, with reference to the load cell capacity: LeverMount® Lite (5-200kg), LeverMount® 300-2500kg and LeverMount® 3000-5000kg.

The load cell is stainless steel, fully welded and hermetically sealed with the highest levels of protection against harsh environments (IP68 and IP69K) and OIML R60 approval to 3000 divisions (C3) or 6000 divisions (C6) for use in legal-for-trade applications. A durable, chemical resistant polyurethane cable is fitted to the load cell as standard. Polyurethane provides greater resistance than PVC to chemicals, UV radiation, temperature changes, pressure cleaning and impacts.

Available load cell options consist of ATEX approval*, a high temperature version and special 'Parylene' coating for aggressive environments where stress corrosion or acid attack is a concern. The mounting accessory is available optionally with a self-centering ball-and-cup load introduction.

- Cast, grade 316 stainless steel mount (3 sizes)
- Fast load cell installation/removal without jacking or dummy/false cells, while vessel is full
- Stable, shim-free 3 point mounting
- Stainless steel, OIML C3 or C6 approved load cell (Ex approval* available)
- Load cell is fully welded and hermetically sealed to IP68 and IP69K; cable sheath is polyurethane
- Version for static applications and dynamic applications (e.g. floor scales)
- Can be mounted radially or tangentially
- Substantial anti-lift protection
- Safer than traditional mounts
- Simple, low cost installation with no specialist tooling required
- Tolerant of steelwork misalignment without errors in output signal
- Allows for large amount of vessel expansion/contraction

LEVERMOUNT®

innovation & inspiration...

THE CONCEPT

Mounting accessories for single shear beam load cells were introduced in the 1980s; today most load cell manufacturers still use these 'traditional' designs that incorporate a threaded jacking feature allowing a vessel to be partially supported by the mount before the load cell is installed. However, under most loading conditions an external hydraulic 'jack' is required to raise and lower the vessel when installing the load cell and the threads can become clogged with dirt or powder – making the 'traditional' jacking mechanism unusable (even at low loads). Also, the 'traditional' 4-point mount design will usually require the time-consuming fitting of shims.

The LeverMount® was specifically designed to offer a completely new approach to process weighing installations. Using the established range of Thames Side bending beam (T66) and shear beam (T85) load cells, the LeverMount® retains the advantages of the 'traditional' mount designs while adding its unique benefits. It provides faster, simpler and safer operation with reduced tooling inventory, when compared with such 'traditional designs'; it also offers improved mechanical stability for the vessel before, during and after the load cell is installed. Thames Side is well known for not just high quality load cells, but a relentless obsession for mounting accessories that engineers across the world specify and rely on as their standard solution.

Two types of load introduction can be specified;

- For hoppers, tanks and vessels: the standard load button and saddle with a slotted interface for expansion and contraction adjustment
- For dynamic applications such as floor scales: the ball-and-cup self-centering (SC) option

INSTALLATION BENEFITS

LeverMount®'s unique and patented design eliminates any need for separate supports, e.g. hydraulic/mechanical jacks or lifting tools, to raise and lower the vessel being weighed.

The base casting, manufactured from grade 316 stainless steel, provides a stable load-bearing platform for the vessel before the load cell is installed.

Once the vessel is in position, the 2 transit bolts are removed and the load cell is used as a lever to raise the top plate of the mount into the weighing position, even when the vessel is full. In the rare event that a load cell should be removed this is done by reversing the procedure.

No hydraulic/mechanical jacks are required for load cell installation/removal. No dummy or false load cells and no specialist tools are required. LeverMount® makes installation, operation and maintenance of the weighing system safer, simpler, faster and less costly.

ATEX CERTIFICATION

The T66 bending beam or T85 shear beam load cells used in the LeverMount® have ATEX certification allowing use in all gas and dust zones. Using the 'ta' mode of protection, these load cells can be used without safety barriers in all dust zones (20, 21, 22) – creating significant cost savings.

Code	Safety Parameters			Application
	Temp. Class	T66 Load Cell	T85 Load Cell	
II 1 GD Ex ia II C T4..T6 Ga IP68 T85°C Ex ia IIIC T135°C T85°C Da Ex ta IIIC T85°C Da	T4	Pi = 2.5W	Pi = 1.3W	Gas Zones 0, 1, 2 with safety barriers
	T5	Pi = 2.5W	Pi = 0.8W	Dust Zones 20, 21, 22 without safety barriers
	T6	Pi = 1.69W	Pi = 0.53W	

* 2,500kg capacity version is not ATEX approved

HIGH TEMPERATURE

The T66 and T85 load cells used in the LeverMount® are available in an optional high temperature version, with special load cell components and a PTFE sheathed cable. This allows operation in environments up to 150°C (continuous operation)

ADDITIONAL PROTECTION

In extreme environments where stress corrosion could occur even in stainless steels, for example where chlorine or acids are present, an optional coating of Parylene can be applied to the T66 or T85 load cells to provide additional protection.

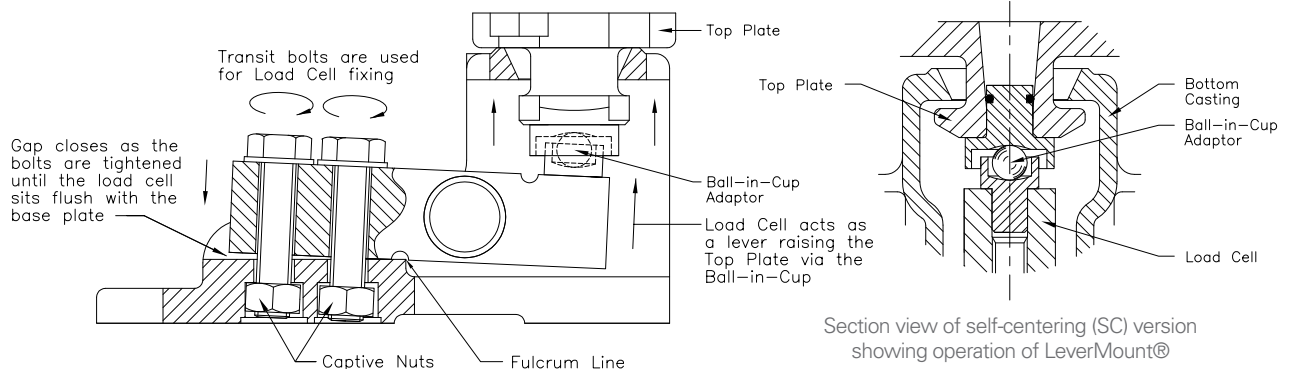

FEATURES	BENEFITS
Purpose designed grade 316 stainless steel mount	Ideal for use in food/pharmaceutical weighing applications
Simple, 2-part casting using the transit bolts for fixing the load cell to the mount	Aesthetically pleasing design, eliminating the need for special bolts which could be lost in transit
Captivated nuts for fixing of load cell to mount. No jacking screws or threaded pillars.	No stripped threads or interference (leading to expensive mount replacement) from material clogging and dirt build-up
Stainless steel, OIML approved, fully welded and hermetically sealed load cell	Ideal for high accuracy, trade approved process weighing applications in the harshest of environments
Load cell acts as a lever to raise/lower the vessel under load	No need for extra lifting devices, such as hydraulic pad jacks, even when vessel is full. Easier, quicker and safer than 'traditional' mounts.
Substantial clearance below the load cell	Eliminates loss of weighing accuracy due to material build-up below the load cell
Three (3) point support and fixing	Eliminates rocking and twisting of the mount – it always finds a plane
Top plate movement in lateral and rotational axes	Tolerant of steelwork misalignment, avoiding any mechanically induced errors
Configurable for radial, tangential and offset mounting	Easy alignment to the radial axis of the vessel to compensate for expansion and contraction
Substantial anti-lift resistance (more than 50% of the maximum rated load)	Increased safety, compared with other designs
Minimal difference between working height and installed (transit) height	Reduces the need to compensate for rigid pipework to/from vessel
Load cell can easily be removed under load, in situ	Reduced downtime. Production does not need to stop if a load cell must be changed.
Three (3) physical sizes cover the entire range from 5kg to 5000kg	Covers the majority of process weighing applications

Possible mounting options

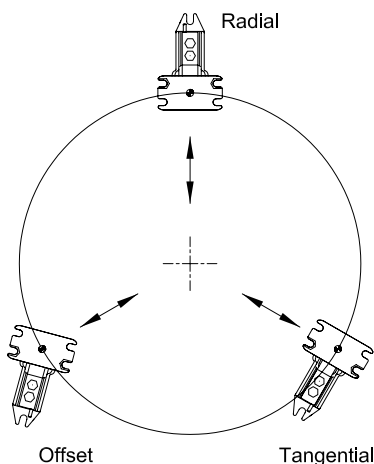

Wiring diagram using 4 core screened cable (T66 and T85)

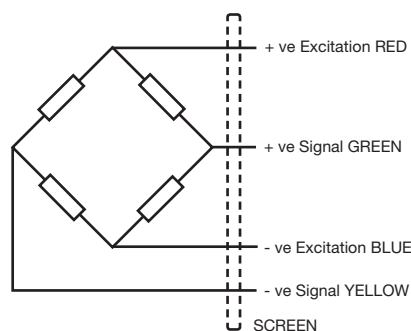

Electrical Connections

Via 4 or 6 core, 5.7mm diameter, screened Polyurethane cable. 6 core cable is only available with T66 load cell (LeverMount® Lite). *Screen not connected electrically to load cell.*

Wiring diagram using 6 core screened cable (T66 only)

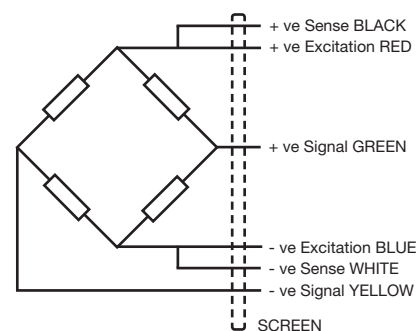

Construction

LeverMount® body is manufactured from cast 316 stainless steel; load introduction parts are manufactured from hardened 17-4PH stainless steel. Load cell is manufactured from stainless steel.

LEVERMOUNT®

technical specification...

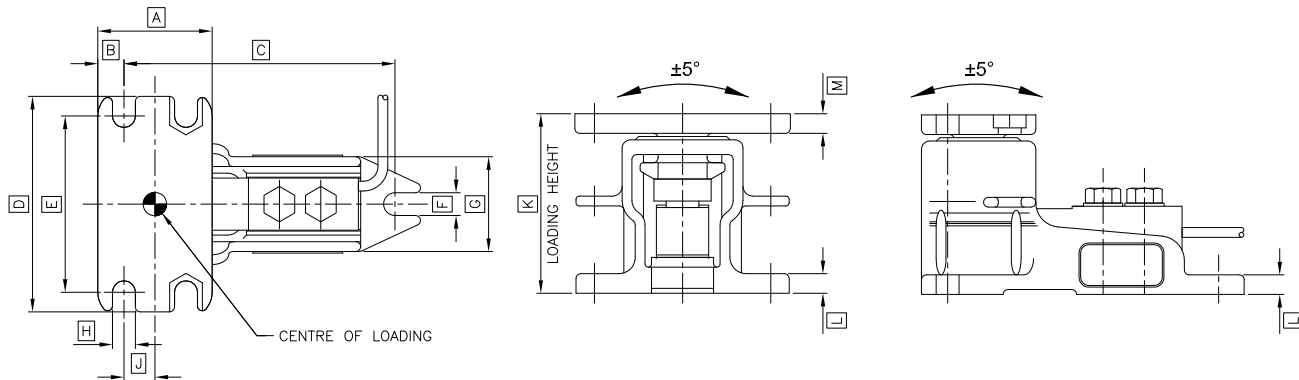

Data for T66 and T85 Load Cells

Loading data for complete LeverMount® assembly is available on request

	Load cell specification		Units	
	LeverMount® Lite	LeverMount®		
Load cell utilised	T66		T85	
Accuracy Class according to OIML R60: number of verification intervals (n)	3000 *	6000	3000	n. OIML
Available load cell capacities (E _{max})	5, 10, 20, 30, 50, 75, 100, 150, 200	50, 75, 100, 150, 200	300, 500, 750, 1000, 1500, 2000, 2500, 3000, 5000	kg
Rated Output (S _n)	2 ± 0.1 % ^Δ		2 **	mV/V
Combined Error	< ± 0.017	< ± 0.008	< ± 0.017	% S _n
Non-repeatability	< ± 0.015	< ± 0.01	< ± 0.015	% S _n
Minimum load cell verification interval (v _{min}) = E _{max} / Y	E _{max} / 10 000	E _{max} / 18 000	E _{max} / 10 000	kg
Creep (30 minutes)	< ± 0.016	< ± 0.008	< ± 0.016	% S _n
Temp Effect on Zero Balance	< ± 0.002	< ± 0.001	< ± 0.002	% S _n /°C
Temp Effect on Span	< ± 0.0012	< ± 0.0006	< ± 0.0012	% S _n /°C
Compensated Temp Range	-10 to +40			°C
Operating Temp Range	-30 to +70			°C
Zero Balance	< ± 2			% S _n
Input Resistance	400			Ω ± 20
Output Resistance	350			Ω ± 3
Insulation Resistance	> 5000			MΩ @ 100v
Recommended Supply Voltage	5-15			V
Maximum Supply Voltage	15			V
Environmental protection according to EN 60529	IP68 and IP69K			-
Maximum deflection at E _{max}	0.2 - 0.4			mm
Cable Length	3	5		m
Cable Material	Polyurethane			-
Nominal Shipping Weight of LeverMount® and load cell	1.2	300-2500kg	4	kg
		3000-5000kg	9	

* T66 load cell: OIML C3 (3000 division) approval is available from 10-200kg

Δ T66 load cell: for 5-20kg capacity range, tolerance of rated output (S_n) is ± 0.2 %

** T85 load cell rated output (S_n): pre-corner adjustment optimised at ± 0.05% by output current calibration

Capacity (kg)	5 - 200 (T66)	300 - 2500 (T85)	3000 - 5000 (T85)
A	70	70	100
B	16	16	25
C	147	168	225
D	100	132	190
E	80	108	150
F	9	14	22
G	55	60	80
H	9	14	22
J	19	19	25
K	80	110	164
L	7	12	15
M	8	12	20

All dimensions in mm.

UK Patent No. 2 339 026
US Patent No. 6 320 142

DISTRIBUTED BY:



THAMES SIDE SENSORS LTD

Unit 10, io Trade Centre, Deacon Way, Reading, Berkshire RG30 6AZ

tel: +44 (0) 118 941 1387

fax: +44 (0) 118 941 2004

sales@thames-side.co.uk

www.thames-side.com



Issue: LeverMount.02.17

LeverMount® is a registered trademark of Thames Side Sensors Limited.

Our policy is one of continuous product enhancement. We therefore reserve the right to incorporate technical modifications without prior notification.



www.thames-side.com

SKT CAL
MB x S
WASHER
TORQUE

BASE PLATE
100
130
100

LOAD CELL
MODEL 300

'A'

'B' CRS

70

90